



PERGAMON

Available online at [www.sciencedirect.com](http://www.sciencedirect.com)

SCIENCE @ DIRECT®

International Journal of  
**HEAT and MASS  
TRANSFER**

International Journal of Heat and Mass Transfer 46 (2003) 3329–3335

[www.elsevier.com/locate/ijhmt](http://www.elsevier.com/locate/ijhmt)

# Study on heat driven pump. Part 1—experimental measurements

J.L. Xu, X.Y. Huang, T.N. Wong \*

*School of Mechanical and Production Engineering, Nanyang Technological University, Nanyang Avenue, Singapore 639798, Singapore*

Received 26 September 2001; received in revised form 12 March 2003

## Abstract

This paper presents an experimental study on heat driven pumps. Two pumps with different configurations were tested, one had a simple U-tube with two check valves, while the other had an additional horizontal branch across the heating section. The dynamics of the pumps were observed in terms of pulsating pressures and temperatures inside the pumps. The pulsating cycle period and the pumping flow rate were measured at various heating powers and the inlet liquid temperatures, and the performance of the pumps were characterized. The thermal hydraulic characteristics of the pulsating cycle at different stages was proposed and discussed.

© 2003 Elsevier Science Ltd. All rights reserved.

## 1. Introduction

The heat driven pump consists of a U-tube with two check valves at both ends, as shown in Fig. 1. The tube is initially filled with fluids and is heated up from the wall. The heating will induce phase change in the fluids and pressure increase inside the tube, so that the fluids will be discharged through the outlet valve, while more fluids are supplied through the inlet valve to complete a cycle for the pumping.

The first prototype of the heat driven pump was constructed by Yamamoto et al. [1,2]. The tubes used for the pumps in their studies had an inner diameter of 11.5 mm. Some preliminary results were reported, such as the increase of the flow rate with the heating power and the critical heating power, below that the pump would not function. Takamura et al. [3,4] studied a heat driven pump which was fabricated with glass tubes and some additional results were reported, including dry-out occurred at high heating power and the visualization of bubble formation during the pump cycle. By heating bubbles to drive fluids in microchannels was

reported by Thomas and Jun [5]. In their study, the input heat created a temperature gradient along the channel, together with a variation of vapor pressures in the bubbles, so that the bubbles were moved in the channel to pump the fluids. The flow rate was low in this design.

The heat driven pumps are of advantages in having simple structures and less mechanical components, and therefore they may have potential application in miniature cooling devices and other fluid delivery systems. In order to optimize the current design of the heat driven pumps and improve their performance, it is necessary to have a better understanding of the thermal hydraulic characteristics of the heat driven pumps, which has not been seen in the published papers and is the motivation of the present study.

Our work consists of two parts, namely, experimental measurement and mathematical modeling. The modeling of the pump system, which is based on a two-phase flow model, will be discussed in a separated paper. The experimental results are presented in this paper, in which the dynamic process of the pumping cycle is evaluated in terms of pressure and liquid temperature variations inside the tube and the pumps performance is characterized in terms of the cycle period and the discharge flow rate.

\* Corresponding author. Tel.: +65-67-92-40-62.

E-mail address: [mtnwong@ntu.edu.sg](mailto:mtnwong@ntu.edu.sg) (T.N. Wong).

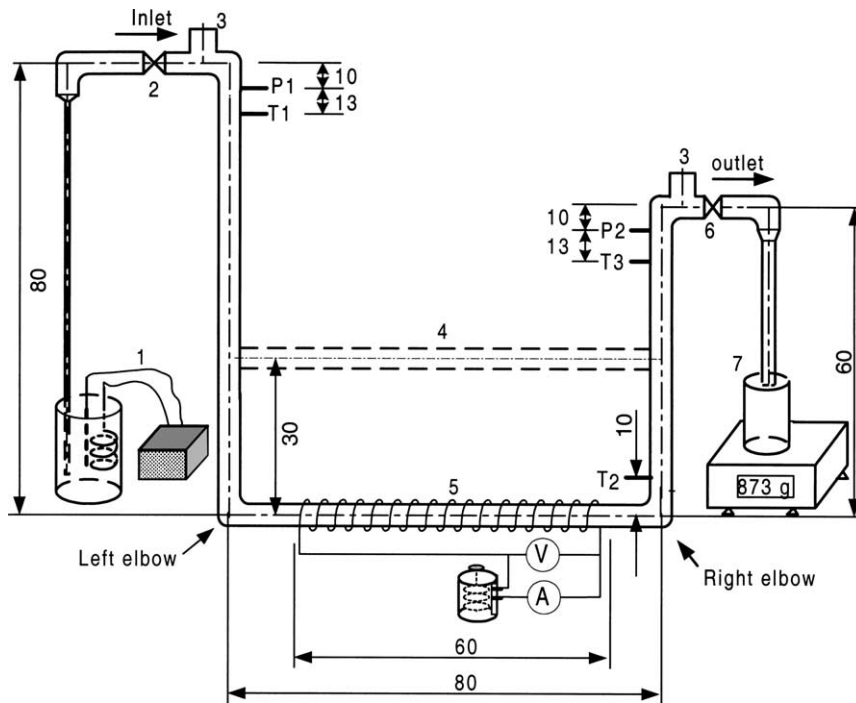

1. inlet temperature control system
2. inlet check valve
3. injection holes
4. horizontal branch (alternative design)
5. heating section
6. outlet check valve
7. flow rate measurement system

Fig. 1. The heat driven pumps and the experimental set-up (all dimensions are in mm).

## 2. Experiment set-up

The basic heat driven pump used in the present study is shown in Fig. 1. To miniaturize the pump for possible electronic cooling application, the glass tubes with an inner diameter of 3.0 mm was used. The overall size of the pump was about 80 mm in height and 80 mm in width, which was quite small comparing with those used in previous studies. The heat driven pumps in the reported studies [1–3] had an additional horizontal tube between the inlet and the outlet, apart from the heating tube. For the purpose of comparison, we also tested a pump configured with the additional horizontal tube of 3 mm inner diameter, which was 30 mm above the bottom heating section. Five T-junctions, which were marked as P1, P2, T1, T2, T3 in Fig. 1, were set at different part of the pumps to facilitate the pressure and temperature measurements. The T-junctions P1 and P2 were connected to the bi-directional Setra-239 pressure sensors which had the pressure range of 25 inch water, accuracy of 0.14% and the response time of 1.0 ms. The

pressure sensor measured the pressure variation relative to the ambient pressure. K type thermocouples with the tip diameter of 0.3 mm were inserted and sealed in the holes of T-junction T1, T2 and T3. The response time of the thermocouple is 1.0 ms. Such response time is fast enough to record the dynamic process of the pump, with the cycle period in the order of several seconds in our measurements. Two injection holes at the top of the test section were used for initial charging. The liquid was charged through the left hole and the non-condensable gas was released through the right hole. The two injection holes were well sealed by the plastic caps after the charging. The working liquid in the present experiments was tap water.

Two 1/8 in. check valves, which were the product of the Lee Company, were used at the inlet and the outlet, and the check valves were carefully selected to have the crack pressure of 4.0 in. water. The heating wire was wound uniformly around the surface of the horizontal heating section and the effective heating length was 60 mm. The heating section was well insulated using the

thick thermal insulation material. The heating power was calculated by measuring the voltage and the current supplied to the heating wire. The heat balance of the dynamic system was confirmed by comparing the heating power and the fluid enthalpy difference between the inlet and the outlet of the system. The liquid temperature in the supply tank was controlled by a temperature controller consisting of a thermocouple and an electronic heater, and the temperature in the supply tank could be controlled within  $\pm 1$  °C. The discharged liquid was collected by a liquid collection tank which was weighted by a BW4200H electronic balance with the accuracy of 0.01 g. The time-averaged discharge flow rate was calculated by weighing the tank over a certain period of time and presented in term of g/h. The dynamic pressure and the liquid temperatures inside the tested pump were recorded by a DL-716 high-speed Data Acquisition System, which was made by YOKOGAWA. The data acquisition system had 16 channels and the signals from the pressure sensors and the thermocouples were processed simultaneously. The dynamic data were recorded when the pump is in the steady oscillating stage, and the normal operation of the pump can last several hours, for most of the experiment run cases. The pump can operate up to 10 h without significant change of the pulsating cycle behavior.

### 3. Results and discussion

The results presented below are mainly from the experiments conducted on the pump with the configuration shown in Fig. 1, unless it is mentioned that the results are from the pump with the horizontal branch.

#### 3.1. Dynamics of pumping cycles

It was observed in the experiments that the heat driven pumps started to operate at the heating powers above a critical value, which depended on the inlet liquid temperature, and the pumping effect was in a pulsating form. Fig. 2 shows the pressure and temperature variations at the sensors P1, P2, T2 and T3 over a typical cycle at the heating power  $Q = 27.4$  W, the inlet water temperature  $T_{in} = 24$  °C and the flow rate of 280 g/h. It is seen that the pressures at P1 and P2 are almost identical, which consist of a positive pulse followed by a negative pulse. This indicates that the boiling and condensation, not the gravity, dominate the dynamic process in the system. The process repeats periodically with the period about 6.8 s in this case. The temperature T1 near the inlet valve was found almost unchanged during the operation cycles, so that only T2 and T3 are plotted in Fig. 2. It is seen that there is a strong temperature pulsating at T2 (near the right elbow) following the pressure variation, while the temperature pulsating at T3

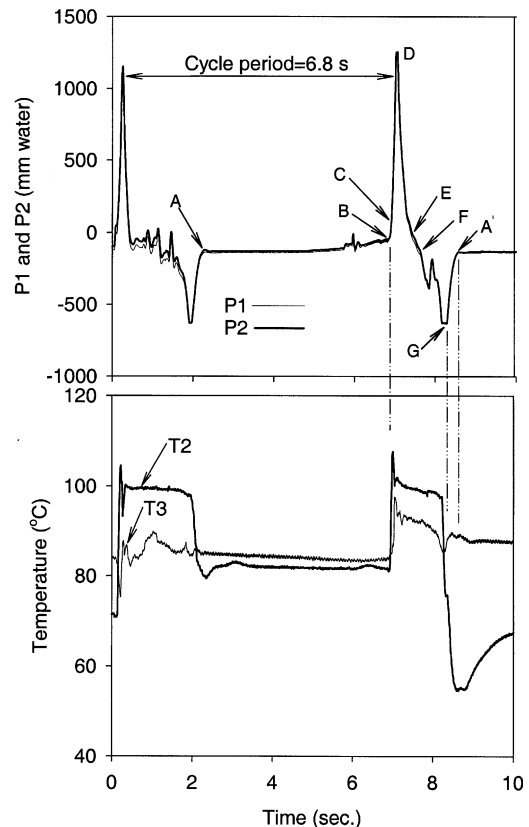

Fig. 2. The pressure and temperature fluctuations for the pump operated at the heating power of 27.4 W, the inlet water temperature  $T_{in} = 24$  °C and the flow rate of 280 g/h.

is not as strong as at T2. In Fig. 2, the complete operation cycle is marked from A to A' in time sequence, and the thermal hydraulic characteristics of the pump system during the cycle may be explained by the illustration in Fig. 3. This was observed by temporarily removal of the heat insulation material during the experiment of low heating density condition. The measurements were performed when the pump is at the steady oscillating stage with the horizontal tube being well heat insulated. The typical stages in time sequence for a full cycle is summarized as follows:

##### 3.1.1. Sensible heating stage (Fig. 3(a) and (b))

In Fig. 2, time A to B was the time taken for sensible heating stage in the horizontal tube. The system with both check valves closed was filled with single-phase liquid (Fig. 3(a)). The heating caused a slight increase in pressure due to the volumetric liquid expansion with a slight variation in temperature at T2 and T3. At time B, the liquid temperature in the heating section has reached to a higher value where boiling was activated. Small bubbles generated at the heating section (Fig. 3(b)).

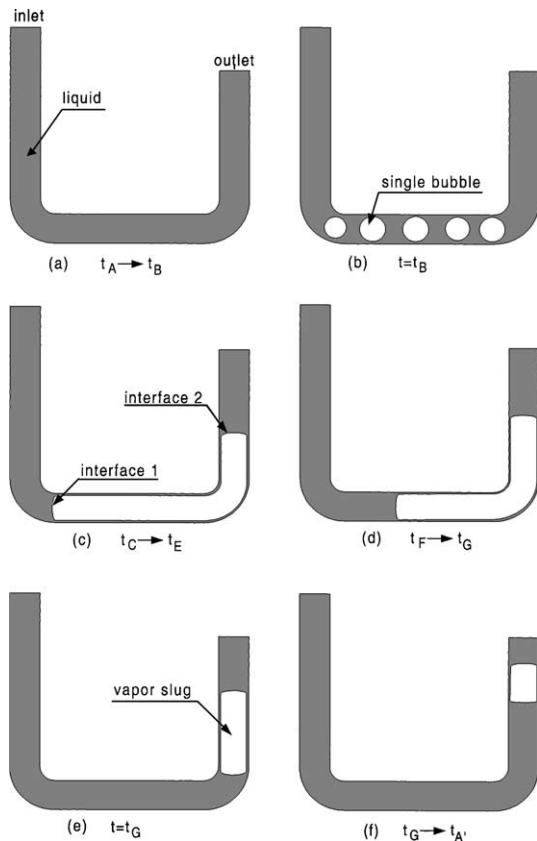

Fig. 3. Dynamics of a pumping cycle.

### 3.1.2. Phase change stage with fluids discharge (Fig. 3(c))

Following time B in Fig. 2, the small sphere bubbles aggregated to form larger vapor slug due to the capillary effect within the small diameter tubes, as illustrated in Fig. 3(c). The pressure increased rapidly to reach the crack pressure of the outlet valve at time C, the outlet valve opened and liquid was discharged. The system obtained a maximum pressure at time D where boiling effect was balanced by both the condensation and fluids discharged. It was noted that the temperature of vapor slug was remained at saturation during the period C to E, as shown in Fig. 2. As the vapor slug moved into the unheated riser section, the condensation occurred. Both fluids discharged and the condensation effect caused the pressure dropped sharply, resulting the shrinkage of the vapor slug. This caused the outlet valve to close at point E when the net pressure difference across the outlet valve became zero.

### 3.1.3. Liquid suction from inlet check valve (Fig. 3(d)–(f))

As more vapor moved into the riser, the pressure dropped further and the inlet valve was triggered to

open at point F, which corresponds to the crack pressure of the inlet valve. Fluids from the supply tank flowed into the system and pushed the vapor slug towards the riser. At the same time the vapor slug was subjected to condensation effect. The degree of the condensation depends on the inlet fluid temperature. Once the interface 1 reached the elbow of the riser, temperature at T2 dropped sharply. This occurred at time G and the system experienced a lowest pressure. From G to A' the suction process continued with a pressure recovering, while the vapor length reduced with time (Fig. 3(f)). At the time A, the system was full of liquid, the inlet valve was closed and a new cycle started. The above cycle analysis, based on the pressure and temperature measurements, provides the basis to be used for the mathematical modeling in a separate paper.

It is seen from Fig. 2 that the temperature T3 is below 100 °C, indicating that the vapor slug condensed completely before reaching the outlet valve. Fig. 2 shows that the outlet valve opens at the positive pressure pulse while the inlet valve is closed, and the inlet valve opens at the negative pressure pulse while the outlet valve is closed. The two valves function alternatively for the effective operation of the pump.

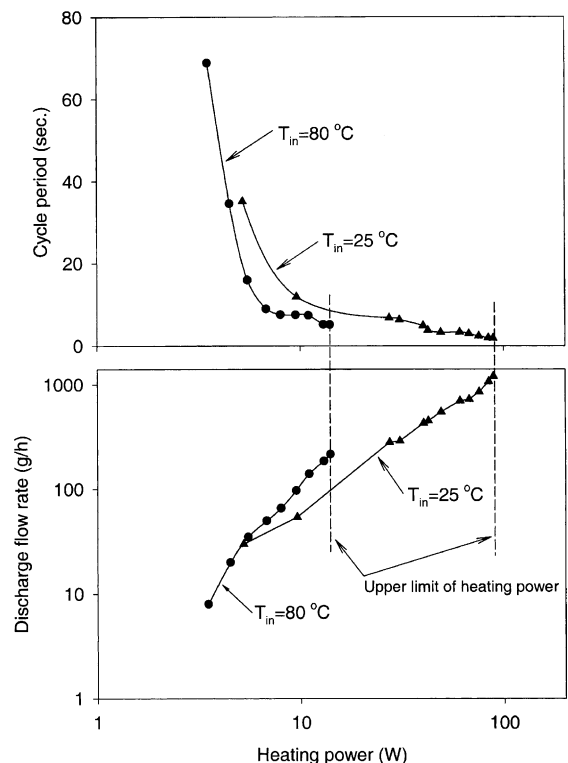

Fig. 4. Performance of the pump (without the horizontal branch) at two different inlet water temperatures  $T_{in} = 25$  and 80 °C.

### 3.2. Characterization of pump performance

The heat driven pumps were characterized by using the cycle period and the delivery flow rate as the output parameters, and the heating power and inlet liquid temperature as the controlled parameters. Fig. 4 shows the plots of the cycle period and the flow rate against the input heating power, with the inlet liquid temperature at 25 and 80 °C respectively. The flow rate is seen increasing as the heating power is increased, while the cycle period dropping quickly, indicating that at higher heating power the flow inside is pulsating faster to deliver more fluids. There is a critical (low-limit) heating power, above which the pump functions. This critical power depends on the inlet liquid temperature, the higher temperature (80 °C) inlet liquid has the lower critical power. There is also an upper-limit heating power, above which the pump will not function. In this case the over heating in the heating section will result in a high pressure in the system to prevent the inlet valve from opening and the dry-out will occur. The higher inlet liquid temperature is seen to have a lower upper-limit heating power, and the overall operation range in

terms of the heating power is smaller comparing to the lower inlet liquid temperature.

The effect of the horizontal branch was observed in the experiment by comparing the performance of pumps with and without the branch. Fig. 5 shows the pulsating of the pressures and temperatures for both pumps at the same heating power of 68 W and the inlet liquid temperature of 27 °C. The results for the pump with the additional branch (Fig. 5(a)) display a shorter cycle period (about 1.5 s) and fewer fluctuations in the temperatures, as compared to a longer cycle period (about 3 s) and large temperature fluctuations for the pump without the horizontal branch (Fig. 5(b)). The effect of the additional branch is probably to enhance the condensation of the vapor slugs by mixing the saturated vapor with the sub-cooled liquid directly from the inlet tube without passing the heating section, so that the operation cycles are shortened and the temperature pulsating is reduced. This is evidenced by the temperature T3 in Fig. 5(a) which is always below 85 °C, indicating that the vapor slugs have been fully condensed before reaching the thermocouple T3. The cycle period and the discharge flow rate are plotted against the heating power

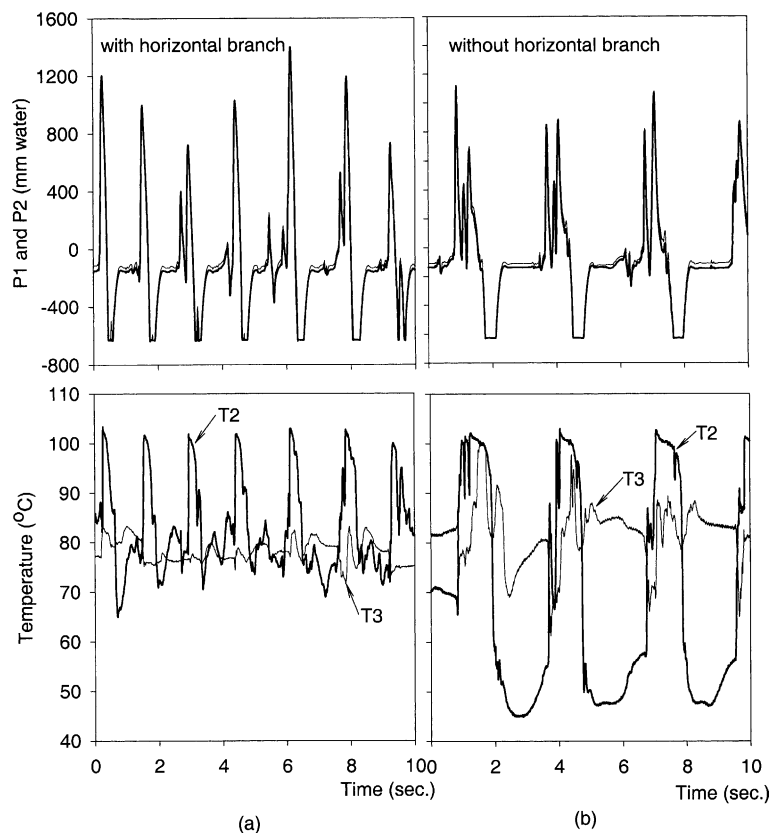

Fig. 5. Effect of the horizontal branch on the pressure pulsating and the temperature fluctuations. The pumps were operated at the same heating power of 68 W and with the inlet water temperature  $T_{in} = 27$  °C. (a) The results with the horizontal branch, and (b) the results without the horizontal branch.

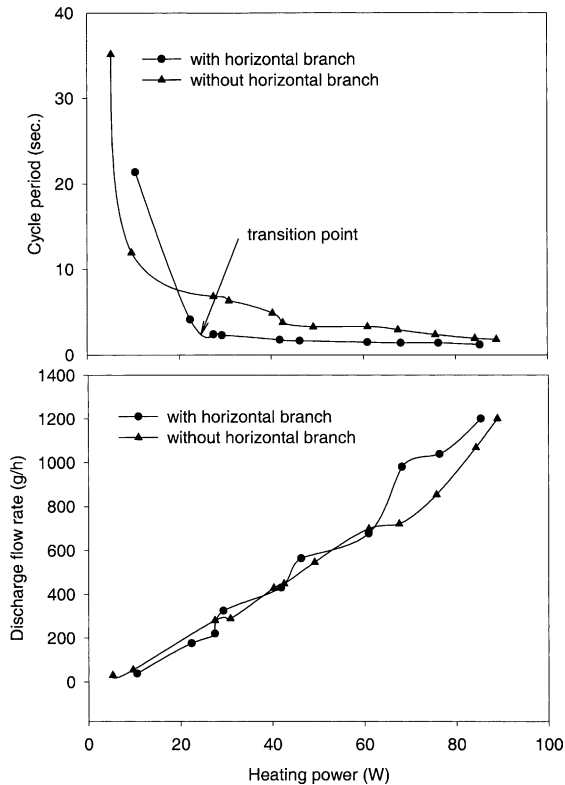

Fig. 6. Performance of the pumps with and without the horizontal branch at the same inlet water temperatures  $T_{in} = 25^\circ\text{C}$ .

in Fig. 6 for both pumps. The results show that the pumps with and without the additional branch basically have a similar operation range in terms of the heating power and the similar discharge flow rate, except at the heating power from 65 to 85 W the pump with the additional branch produce higher flow rate.

It is interesting to note from Figs. 4 and 6 that the pulsating cycle periods sharply drop during the initial stage when the heating powers are just over the critical values, and vary much slowly and smoothly when the heating powers are getting high. This is especially true for the pump with the additional horizontal branch, shown in Fig. 6, where the cycle period drops from 21 to 2.5 s when the power is increased from 10.5 to 26 W, but only changes from 2.5 to 1.3 s over the range from 26 to 90 W. It seems that there is a transition point in the heating power, over which the pump system is settled down to a more steady oscillation state.

#### 4. Conclusions

Measurements were conducted to evaluate the performance of the heat driven pumps with two different configurations, one had simply a U-tube with two

check valves and the other had an additional horizontal branch across the heating section between the inlet tube and the outlet tube. The dynamic pressures and the temperature pulsating inside the pumps were recorded and the pumping performance were characterized in terms of the pulsating cycle periods and the discharge flow rates. The new findings are summarized as follows.

1. The pressures at the locations P1 and P2 are almost identical during the dynamic cycles of the pumping process, indicating that the pressures are boiling and condensation controlled, i.e., and inside the system the pressures are balanced by the boiling in the heating section, the condensation of the saturated vapor and the liquid discharge through the outlet valve.

2. During one cycle, the two check valves function alternatively and there is no time when both of them open or closed simultaneously.

3. The operation cycle period is affected by the heating power. At the initial stage when the heating power is low the cycle period drops quickly as the power increased, and then it approaches a constant value at higher heating pressure.

4. An operation range in terms of the heating power is found for a given pump, out of this range the pump will not function, either because the boiling at the heating section is not strong enough to produce the negative pressure pulse for the inlet valve to open, or because the boiling is too strong to keep the inlet valve from opening. The operation power range is greatly affected by the inlet liquid temperature.

5. The heat driven pump with the additional horizontal branch will shorten the pulsating cycle periods and smooth the temperature fluctuations. However, its discharge flow rate and the operation power range are not much different from the one without the horizontal branch.

#### Acknowledgements

This work is part of a research project on microscale cooling technology, which is financially supported by the National Science and Technology Board and the Ministry of Education of Singapore.

#### References

- [1] T. Yamamoto, Y. Takamura, M. Katsuta, Study of heat driven pump, *J. Fuel Soc. Jpn.* 59 (644) (1980) 1016–1024.
- [2] T. Yamamoto, Y. Takamura, M. Katsuta, Study of heat driven pump, *J. Fuel Soc. Jpn.* 12 (1) (1982) 19–24.
- [3] Y. Takamura, T. Yamamoto, M. Katsuta, Proposal heat driven pump for heat device, in: *Proceedings of the*

- International Conference on Energy and Environment, May 1995, p. 538.
- [4] Y. Takamura, T. Yamamoto, S. Matsumoto, M. Katsuta, Development of downward heat pipe using principle of heat driven pump, energy and environment, in: K. Chen, G. Sarlos, T.W. Tong (Eds.), Proceedings of the International Conference on Energy and Environment, Shanghai, China, May 1998.
- [5] K. Thomas, C.-J. Jun, Valveless pumping using traversing vapor bubbles in micro-channels, *J. Appl. Phys.* 28 (11) (1998) 5658–5664.